

ET16F

MECCALTE spa - Via Roma, 20 - 36051 CREAZZO (VI) ITALY
Tel. +39 0444/396111 - Fax +39 0444/396166 - e-mail: info@meccalte.it
website: www.meccalte.com

3-PH. 2 POLE IP23

BRUSH + AVR

CHARACTERISTICS

POWER 230/400V AT 3000 RPM - 50 Hz

Type	CL. H ($\Delta T=125^{\circ}\text{C}$)						CL. F ($\Delta T=105^{\circ}\text{C}$)		STAND BY ($\Delta T=163^{\circ}\text{C}$)		CL. H ($\Delta T=125^{\circ}\text{C}$)		T.H.D. %
	THREE-PHASE		MOTOR STARTING CAPABILITY kVA	EFFICIENCY %			THREE-PHASE		AMBIENT TEMPERATURE 27°C		SINGLE-PHASE DELTA CONNECTION		
	kVA	KW COS φ 0,8		2/4	3/4	4/4	kVA	kW COS φ 0,8	kVA	kW COS φ 0,8	kVA COS φ 1	MOTOR STARTING CAPABILITY kVA	
ET16F-130	5,5	4,4	9,5	76,1	80,4	80,2	5	4	5,8	4,6	3,6	7	< 5
ET16F-160	6,5	5,2	10,5	78,5	82,7	82,3	5,8	4,6	7	5,6	4,3	8,5	< 5

POWER 277/480V AT 3600 RPM - 60 Hz

Type	CL. H ($\Delta T=125^{\circ}\text{C}$)						CL. F ($\Delta T=105^{\circ}\text{C}$)		STAND BY ($\Delta T=163^{\circ}\text{C}$)		CL. H ($\Delta T=125^{\circ}\text{C}$)		T.H.D. %
	THREE-PHASE		MOTOR STARTING CAPABILITY kVA	EFFICIENCY %			THREE-PHASE		AMBIENT TEMPERATURE 27°C		SINGLE-PHASE DELTA CONNECTION		
	kVA	KW COS φ 0,8		2/4	3/4	4/4	kVA	kW COS φ 0,8	kVA	kW COS φ 0,8	kVA COS φ 1	MOTOR STARTING CAPABILITY kVA	
ET16F-130	6,6	5,3	11,4	76,5	80,8	80,6	6	4,8	7	5,6	4,3	8,5	< 5
ET16F-160	7,8	6,2	12,5	78,5	82,8	82,5	7	5,6	8,4	6,7	5,2	10,2	< 5

Type	J (Kgm ²)	Weight (Kg)	Air Volume (m ³ /min)		Noise dB(A)			
			50 Hz		60 Hz		60 Hz	
			50 Hz	60 Hz	7m	1m	7m	1m
ET16F-130	0,0129	30	3,4	4,3	60	78	62	80
ET16F-160	0,0156	34	3,4	4,3	60	78	62	80

TYPICAL ELECTRICAL DATA

Type		ET16F-130	ET16F-160
Rating "H" class	kVA 50 Hz	5,5	6,5
Direct - axis synchronous reactance	X _d %	303	249
Direct - axis transient reactance	X' _d %	40,8	38,1
Direct - axis subtransient reactance	X'' _d %	20	18,6
Quadrature - axis synchronous reactance	X _q %	100	96,2
Quadrature - axis transient reactance	X' _q %	100	96,2
Quadrature-axis subtransient reactance	X'' _q %	37,2	35,5
Negative - sequence reactance	X ₂ %	21,6	18,6
Zero sequence reactance	X ₀ %	8,2	7,1
Transient time constant	T' _d (ms)	41	38
Subtransient time constant	T'' _d (ms)	10	9
Armature time constant	T _α (ms)	5	6
Open circuit time constant	T' _{do} (s)	0,8	0,9
Short - circuit ratio	K _{cc}	0,82	0,85
Stator winding resistance	Ω	1,5	1,15

ELECTRONIC REGULATOR	PARALLEL DEVICE	THERMAL PROTECTION			HEATERS	MECHANICAL PROTECTION		
ASR		PTC	BIMET DEVICE.	PT100		IP21	IP23	IP45
●		□	□	□	□		●	□

● = Standard

□ = Optional



OVERALL SIZE, STANDARD TYPE

dimensions in mm

FORM B14

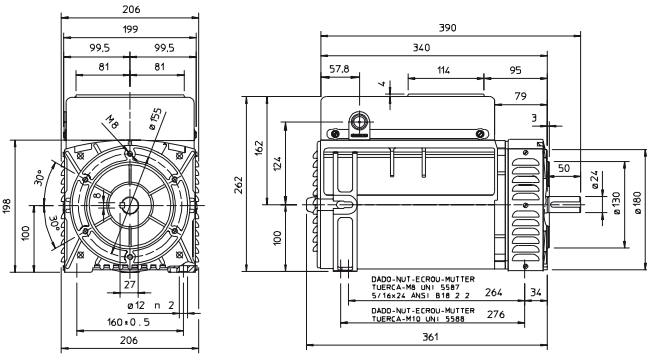

FORM J609a

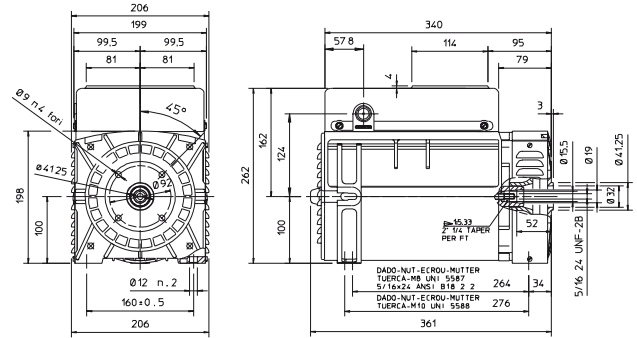

FORM B9/c23

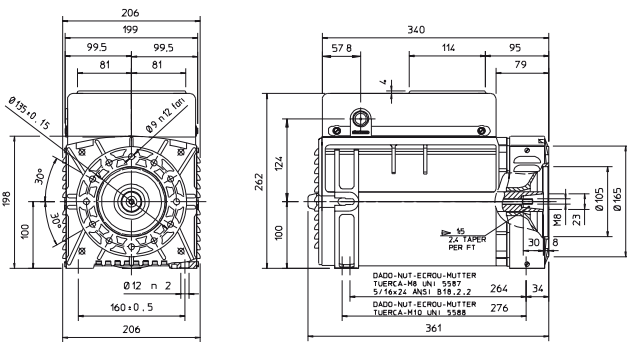

FORM J609b

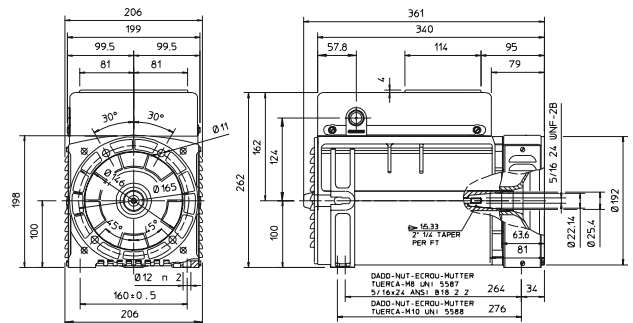

OVERALL SIZE WITH ELECTRIC PANELBOARD TYPE

dimensions in mm

FORM B14

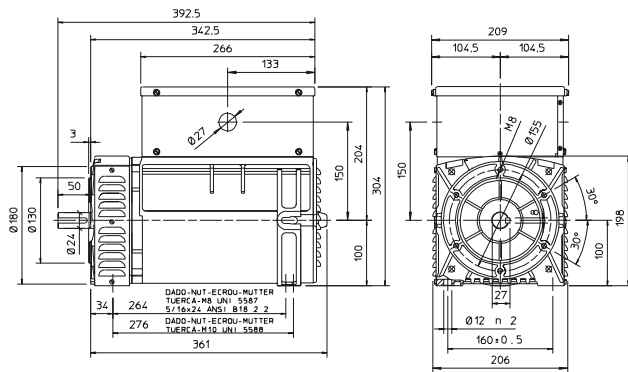

FORM J609a

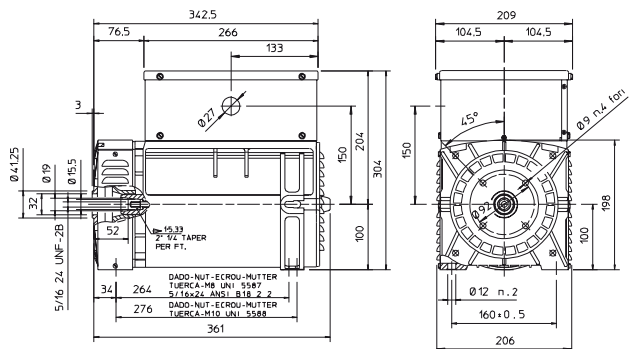

FORM B9/c23

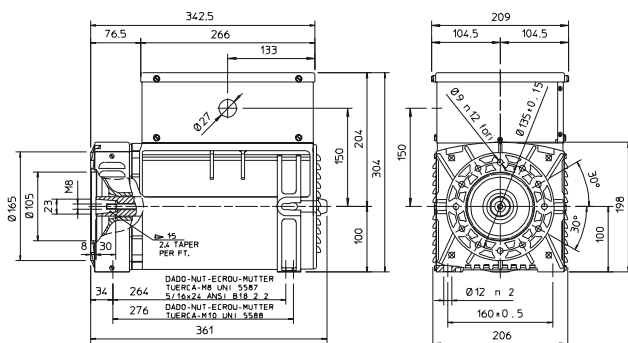

FORM J609b

