

Speed rpm	Type of Operation	Engine Output		Typical Generator Output* (Net)		
		Gross kWm	Net kWm	kVA	kWe	alter.
1500 (50hz)	ESP	183	178	210	168	94.5%
	PRP/DCP	177	172	203	162	94.5%
	COP	124	119	140	112	94.5%
1800 (60hz)	ESP	200	200	240	192	96.0%
	PRP/DCP	197	197	236	189	96.0%
	COP	138	138	166	132	96.0%

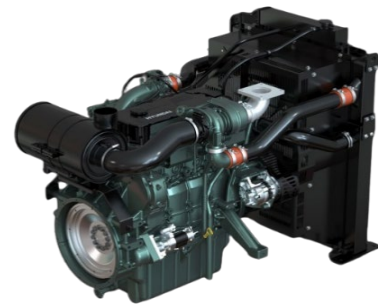

* Ratings Definitions

The power ratings of Emergency Standby and Prime are in accordance with ISO 8528. Fuel Stop power in accordance with ISO 3046. The typical generator output shown is an estimation. Consult your local application engineer for engine selection support and actual OEM genset power output calculation. Also, it must be considered alternator efficiency, altitude derating and ambient temperature.

ESP(STANDBY POWER) is applicable for supplying emergency power for the duration of the utility power outage. No overload capability is available for this rating. A standby rated engine should be sized for a maximum of an 70% average load factor and 200 hours of operation per year. This includes less than 25 hours per year at the Standby Power rating.

PRP(PRIME POWER) is available for an unlimited number of hours per year in variable load application. Variable load should not exceed a 70% average of the Prime Power rating during any operating period of 24 hours. The Total operating time at 100% Prime Power shall not exceed 500 hours per year. A 10% overload capability is available for a period of 1 hour within a 12 hours period of operation. Total operating time at the 10% overload power shall not exceed 25 hours per year.

COP(CONTINUOUS POWER) is defined as being the maximum power which the generating set is capable of delivering continuously whilst supplying a constant electrical load when operated for an unlimited number of hours per year under the agreed operating conditions with the maintenance intervals and procedures being carried out as prescribed by the manufacturer.

DCP(DATA CENTRE POWER) is available for variable or continuous electrical loads in a data centre application. Up to 100 percent load factor is permitted for unlimited time. DCP power definition relies on ISO 8528-1 2018 standard to be followed by generator set manufacturer, and will support Tier I to Tier IV classifications of data centres as per UPTIME institute guidelines.

This definition is only back up a reliable utility.

Continuous operation at load is available as after approval of Engine manufacturer (HDI).

General Engine Data

• Engine Suffix	DX05-MFG00
• Emission Compliance	EU Stage V
• Engine Type	4-cycle, In-line, Diesel engine
• Number of Cylinders	4-cylinder
• Bore x Stroke	110 x 132 mm
• Displacement	5,018
• Compression Ratio	16.6 : 1
• Compression Pressure	
• Rotation	Counter clockwise viewed from Flywheel
• Firing Order	1-3-4-2
• Aspiration	Turbo charged & Intercooled (air to air)
• Injection Timing	Controlled by ECU
• Dry Weight	820 kg(With Fan)
• Dimension (LxWxH)	1,311 x 967 x 1,237 mm
• Flywheel Housing	SAE NO.3M
• Flywheel Size	Clutch NO.11-1/2"
- Number of Teeth	131

Engineering Data

• Maximum Bending Moment at Rear Face to Block	-
• Maximum Intake Air Restriction	6.3kPa
• Maximum Exhaust Back Pressure	25kPa
• Maximum Static Pressure After Radiator	0.125kPa
• Maximum CAC Pressure Drop	10kPa
• Maximum Turbine Inlet Gas Temperature	760°C at ESP 730°C at PRP&COP
• ATB	62°C (Cooling fan inlet air temp.)
• Valve System Type	Over head valve
• Number of Valves	Intake 2, exhaust 2 per cylinder
• Valve lashes at cold	N/A (Hydraulic Lash Adjustment)
• Valve timing	Opening Close
- Intake valve	16° BTDC 39° ABDC
- Exhaust valve	43° BBDC 23° ATDC

Electrical System

• Alternator	27.5V x 45A
• Voltage Regulator	Built-in type IC regulator
• Starting Motor	24V x 6.0kW
• Battery Voltage	24V
• Battery Capacity	200Ah x 2ea (recommended)
• Starting Aid (Option)	N/A
• Cold start	-20°C Without heater: In 20sec 25°C Without heater: In 3sec

Cooling System

• Cooling Method	Fresh water forced circulation
• Water Capacity	12.5 liter (engine only) 26 liter (with radiator)
• Water flow rate	338liter/min@1500rpm 405liter/min@1800rpm
• Pressure CAP	90kPa
• Water Temperature	Maximum : 110°C Before start of full load : 40.0°C
• Water Pump	Centrifugal type driven by belt
• Thermostat type and range	Wax-pellet type, Opening temp 71°C, Full open temp 85°C
• Cooling Fan	Blower type, Ø680mm, 9 blades
• Water Pump Path	1Path, 1Line

Fuel System

• Injection Pump	Bosch CP4
• Governor	Controlled by ECU
• Speed Drop	G3 Class (ISO 8528)
• Feed Pump	Gear type
• Injection Nozzle	Multi hole type
• Max. Injection Pressure	1800bar
• Opening Pressure	Controlled by ECU
• Fuel Filter	Full flow, Cartridge type
• Maximum Fuel Inlet Restriction	N/A
• Maximum Fuel Return Restriction	N/A
• Fuel Inlet Pressure Requirement	0.5~1bar(abs)
• Fuel Outlet Pressure Requirement	0.6~1.2bar(abs)
• Fuel Feed Pump Capacity	450liter/hr@1500rpm, 450liter/hr@1800rpm
• Used fuel	Korea : ENFORCEMENT RULE OF CLEAN AIR CONSERVATION ACT ATTACHED TABLE 33 DIESEL North America : ASTM D975C-15 Grades 1D or 2D Europe : EN 590: 2013+A1:2017 Japan : JIS K2204:2007

Lubrication System

• Lubrication Oil	SAE 10W40 (API CK-4 grade)
• Lub. Method	Fully forced pressure feed type
• Oil Pump	Gear type driven by crankshaft gear
• Oil Filter	Full flow, cartridge type
• Oil Pan Capacity	High level 26 liter Low level 15 liter
• Maximum Oil Temp.	130°C
• Lub Oil Pressure	Idle speed : Min 100 kPa Rated speed @ 1500RPM : Min 250 kPa Rated speed @ 1800RPM : Min 300 kPa

Performance data

		ESP	PRP	COP		
• Governed Engine Speed	rpm	1500	1500	1500		
• Engine Idle Speed	rpm	800	800	800		
• Over Speed Limit	rpm	2160	2160	2160		
• Gross Engine Power Output	kW	183	177	124		
• Break Mean Effective Pressure	Mpa	3.08	2.81	1.97		
• Mean Piston Speed.	m/s	6.6	6.6	6.6		
• Specific Fuel Consumption						
25% load	liters/hr	12.2	11.9	9.1		
50% load	liters/hr	21.8	21.2	15.6		
75% load	liters/hr	31.7	30.8	22.2		
100% load	liters/hr	41.8	40.5	28.9		
• Fan Power	kW	5.3	5.3	5.3		
• Sound Pressure at 1m (Without Fan)		95.4	95.0	92.7		
• Intake Air Flow	m ³ /min	11.2	11.1	9.9		
• Exhaust gas temp. after turbo	°C	683	675	515		
• Exhaust gas flow	m ³ /min	31.9	31.3	25.0		
• Heat rejection to coolant	kW					
50Hz(1500 rpm)		65	65	65	65	65
60HZ(1800 rpm)		72	72	72	72	72
• Heat rejection to intercooler	kW					
50Hz(1500 rpm)		38	38	38	38	38
60HZ(1800 rpm)		42	42	42	42	42
• Cooling water circulation	liliters/min					
50Hz(1500 rpm)		338	338	338	338	338
60HZ(1800 rpm)		405	405	405	405	405
• Cooling fan air flow	m ³ /min	228	228	228		

Derating from ISO 3046 Standard Conditions

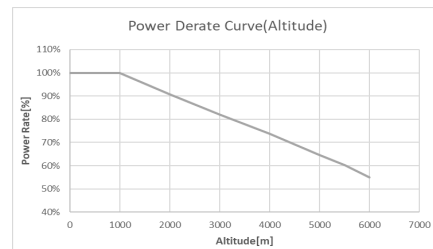
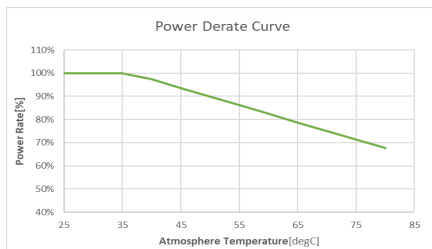

Engine Dimension

- Dimension With Out Rad (LxWxH) : 1,096 x 887.3 x 1282 mm
- Dimension With Rad (LxWxH) : 653.5 x 907 x 1,226.5 mm

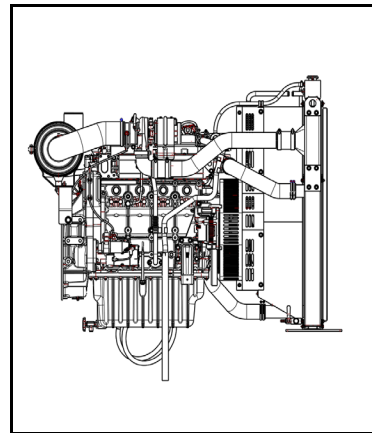
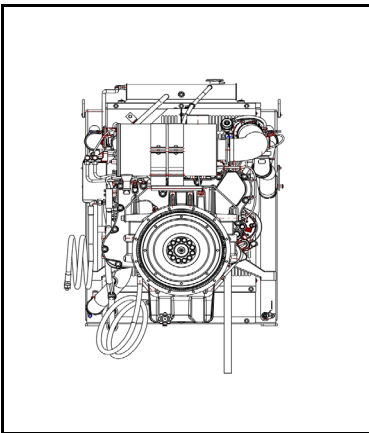
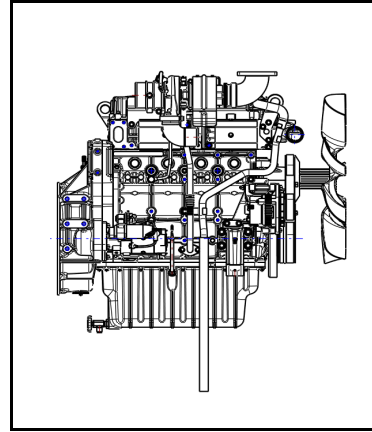
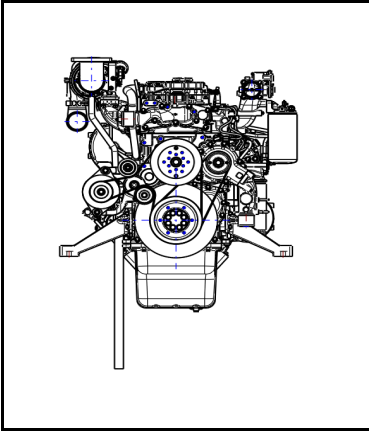

Conversion Table

in = mm x 0.0394

ps = kW x 1.3596

psi = kg/cm² x 14.2233

in³ = lit. x 61.02

hp = PS x 0.98635

lb = kg x 2.20462

lb/ft = N.m x 0.737

U.S. gal = lit. x 0.264

kW = 0.2388 kcal/s

lb/PS.h = g/kW.h x 0.00162

cfm = m³/min x 35.336

HD Hyundai Infracore Co., Ltd.

13F, HD Hyundai Group's Global R&D Center, 477, Bundangsuseo-ro

Bundang-gu, Seongnam-si, Gyeonggi-do, Korea(13553)

Tel : +82 32 211 1114

E-mail : enginesales@hd.com

Website : www.hd-hyundaiengine.com



※ Specifications are subject to change without prior notice.