

DP086LA

DESCRIPTION

- Easy installation, high performance, fuel efficiency and durability are what engine users always need and can be found in DP086 Series engine.
- With Hyundai's engineering expertise, DP086 engines obtain the maximum power output and fuel efficiency while maintaining mechanical type that helps customers manage an engine more easily and conveniently.
- The most appealing part is the simple design minimizing an impact of installation and maintenance.



FEATURES & BENEFITS

[High Fuel Efficiency]

- Improved fuel efficiency
- Fuel consumption reduction thanks to stable combustion

[High Durability]

- New and strengthened key parts
- Improved durability with reinforced exhaust manifold
- High performance radiator

[Easy Installation]

- Redesigned engine mounting bracket
- Repositioned turbochargers
- Easy installation in cold region

[Easy Maintenance]

- Mechanical type engine
- Commonality of key parts

OUTPUT

1,500 RPM (50Hz)									1,800 RPM (60Hz)								
Standby			Prime			Continuous			Standby			Prime			Continuous		
kWm	kWe	kVA	kWm	kWe	kVA	kWm	kWe	kVA	kWm	kWe	kVA	kWm	kWe	kVA	kWm	kWe	kVA
224	204	255	204	185	231	143	128	160	253	228	285	230	206	258	161	142	178

- Generator efficiency (typical) : 93.0%
- kWm= kilo Watt mechanical, Gross power; kWe= kilo Watt electric = (kWm-Fan loss) x Generator eff.
kVA= kilo Volt Ampere
Calculations based on a 0.8 power factor = kWe/0.8

DP086LA

GENERAL DATA

Type	Diesel, Water cooled, Turbo charged & Intercooled
Bore	111mm
Stroke	139mm
Displacement liter	8.07
Cylinders and Arrangement	Cast iron, 6 Cylinder, In-line Type
Battery charging alternator	28.5V x 45A alternator
Starting voltage	24V
Fuel system	Mechanical Injection Pump
Fuel filter	Full flow, Cartridge type with water drain valve
Lube oil filter type (s)	Full flow, Cartridge type
Lube oil capacity (l)	Max. 15.5 liters , Min. 12 liters
Flywheel dimensions	SAE NO. 1M / Clutch NO. 14 M

COOLING SYSTEM

Cooling method	Fresh water forced circulation	
Cooling ratio	50% ethylene glycol; 50% water	
Water capacity (L)	with radiator	44liters
	Without radiator	14liters
Fan power (kW)	5kW(50Hz), 8kW(60Hz)	
Cooling system air flow (m ³ /min)	3.73	

FUEL CONSUMPTION

1,500 RPM (50Hz)

%	kWm	BHP	Liters/hr	USgal/hr
Standby Power				
100	224.0	300.4	54.4	14.37
Prime Power				
100	204.0	269.5	48.7	12.87
75	153.0	202.2	36.8	9.72
50	102.0	134.8	24.6	6.50
25	51.0	67.4	13.0	3.43
Continuous Power				
100	143			

1,800 RPM (60Hz)

%	kWm	BHP	Liters/hr	USgal/hr
Standby Power				
100	253.0	339.3	62.9	16.62
Prime Power				
100	230.0	305.7	56.0	14.79
75	172.5	229.3	41.7	11.02
50	115.0	152.9	28.3	7.48
25	57.5	76.4	15.5	4.09
Continuous Power				
100	161.0			

DP086LA

DIMENSIONS

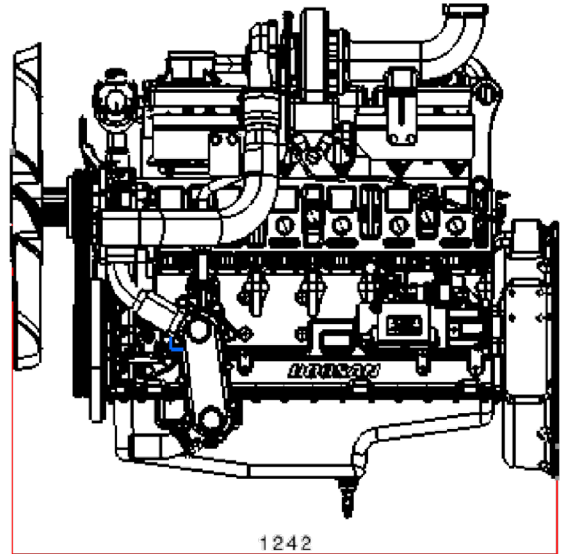
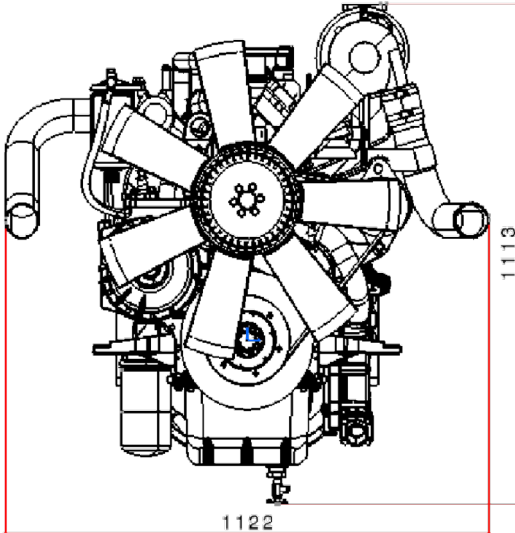

Weights and Dimensions

Item	Length (mm)	Width (mm)	Height (mm)	Dry Weight (kg)
Engine	1,242	1,122	1,113	790

POWER RATING GUIDE

The power ratings of Emergency Standby and Prime are in accordance with ISO 8528. Fuel Stop power in accordance with ISO 3046. Electric power (kWe) must be considered cooling fan loss, alternator efficiency, altitude derating and ambient temperature.

ESP(STANDBY POWER) is applicable for supplying emergency power for the duration of the utility power outage. No overload capability is available for this rating. A standby rated engine should be sized for a maximum of an 70% average load factor and 200 hours of operation per year. This includes less than 25 hours per year at the Standby Power rating.

PRP(PRIME POWER) is available for an unlimited number of hours per year in variable load application. Variable load should not exceed a 70% average of the Prime Power rating during any operating period of 24 hours. The Total operating time at 100% Prime Power shall not exceed 500 hours per year. A 10% overload capability is available for a period of 1 hour within a 12 hours period of operation. Total operating time at the 10% overload power shall not exceed 25 hours per year.

COP(CONTINUOUS POWER) is defined as being the maximum power which the generating set is capable of delivering continuously whilst supplying a constant electrical load when operated for an unlimited number of hours per year under the agreed operating conditions with the maintenance intervals and procedures being carried out as prescribed by the manufacturer.

※ Specifications are subject to change without prior notice.

HD Construction Equipment Co., Ltd.

HD Hyundai Group's Global R&D Center, 477, Bundangsuseo-ro, Bundang-gu, Seongnam-si, Gyeonggi-do, Korea (13553)
hd.engine@hd.com / www.hd-hyundaiengine.com

HD CONSTRUCTION EQUIPMENT