



GENERATOR



11.1L / 6 CYLINDERS

50/60Hz
Multi Frequency
Generator

SWITCHABLE

DESCRIPTION

- DP126 Series has been born with two years of effort from HD Construction Equipment, the company with excellent track record of designing superb engine design techniques.
- When compared to other engines in its class that are manufactured by competitors, it displays a higher output, fuel efficiency, safety, and easier maintenance.

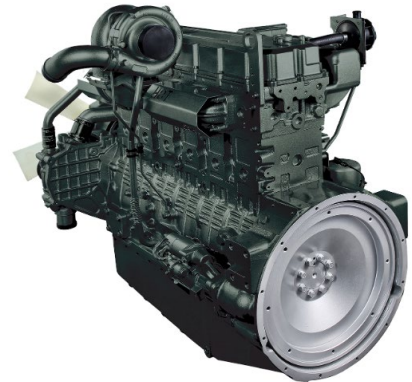

FEATURES & BENEFITS

[Increased Output]

- Higher liter per power than P126TI series

[Economic Efficiency]

- Developed to have the lowest fuel consumption in its class
- By applying impactor as a standard, oil carryover has been minimized
- Improved oil pan size allows operation of 500 hours
- Anti-drain bowl shape and anti-drain back valve oil contamination applied

[Easy Maintenance]

- Auto tensioner is applied

OUTPUT

1,500 RPM (50Hz)									1,800 RPM (60Hz)								
Standby			Prime			Continuous			Standby			Prime			Continuous		
kWm	kWe	kVA	kWm	kWe	kVA	kWm	kWe	kVA	kWm	kWe	kVA	kWm	kWe	kVA	kWm	kWe	kVA
321	295	369	293	269	336	205	186	233	375	342	428	346	315	394	242	217	271

- Generator efficiency (typical) : 94.0%
- kWm= kilo Watt mechanical, Gross power; kWe= kilo Watt electric = (kWm-Fan loss) x Generator eff.
kVA= kilo Volt Ampere
Calculations based on a 0.8 power factor = kWe/0.8

DP126LA

GENERAL DATA

Type	Diesel, Water cooled, Turbo charged & Intercooled
Bore	123mm
Stroke	155mm
Displacement liter	11.05
Cylinders and Arrangement	Cast iron, 6 cylinder, In-line Type
Battery charging alternator	24V x 80A alternator
Starting voltage	24V
Fuel system	Mechanical Injection Pump
Fuel filter	Main(On Engine): Full flow, High efficiency dust in fuel filter, cartridge type Pre(Loosed Part): Full flow, cartridge type with water drain valve
Lube oil filter type (s)	Full flow, cartridge type
Lube oil capacity (l)	Max. 44 liters , Min. 20 liters
Flywheel dimensions	SAE NO. 1M / Clutch NO. 14 M

COOLING SYSTEM

Cooling method	Jacket Water and Charge Air Cooled	
Cooling ratio	50% ethylene glycol; 50% water	
Water capacity (L)	with radiator	51liters
	Without radiator	23liters
Fan power (kW)	16kW(50Hz), 24kW(60Hz)	
Cooling system air flow (m ³ /min)	5.2(50Hz), 8.8(60Hz)	

FUEL CONSUMPTION

1,500 RPM (50Hz)		
%	kWm	Liters/hr
Standby		
100	321.0	74.3
Prime		
100	293.0	68.1
75	219.8	51.1
50	146.5	34.3
25	73.3	17.9
Continuous		
100	205.0	

1,800 RPM (60Hz)		
%	kWm	Liters/hr
Standby		
100	375.0	87.9
Prime		
100	346.0	80.5
75	259.5	60.1
50	173.0	40.8
25	86.5	22.5
Continuous		
100	242.0	

DP126LA

DIMENSIONS

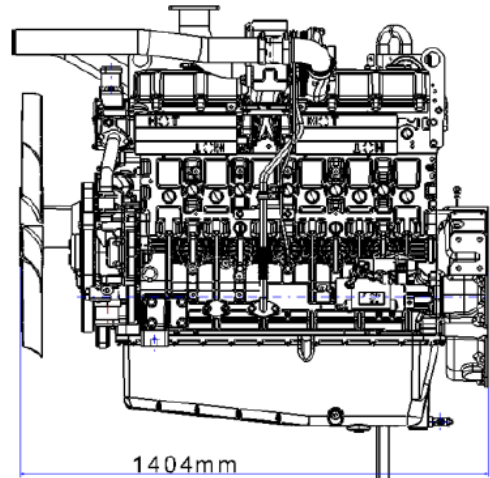
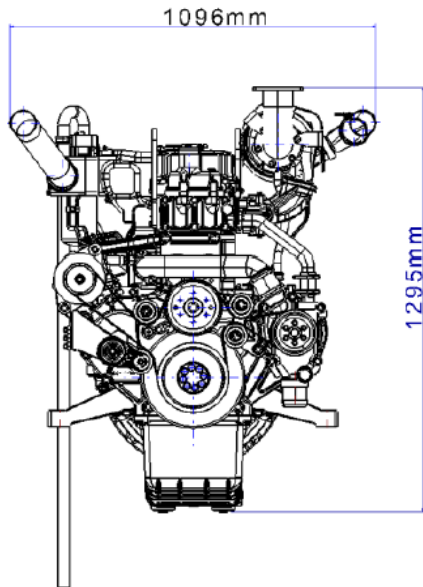

Weights and Dimensions

Item	Length (mm)	Width (mm)	Height (mm)	Dry Weight (kg)
Engine	1,404	1,096	1,295	1,008

POWER RATING GUIDE

The power ratings of Emergency Standby and Prime are in accordance with ISO 8528. Fuel Stop power in accordance with ISO 3046. Electric power (kWe) must be considered cooling fan loss, alternator efficiency, altitude derating and ambient temperature.

ESP(STANDBY POWER) is applicable for supplying emergency power for the duration of the utility power outage. No overload capability is available for this rating. A standby rated engine should be sized for a maximum of an 70% average load factor and 200 hours of operation per year. This includes less than 25 hours per year at the Standby Power rating.

PRP(PRIME POWER) is available for an unlimited number of hours per year in variable load application. Variable load should not exceed a 70% average of the Prime Power rating during any operating period of 24 hours. The Total operating time at 100% Prime Power shall not exceed 500 hours per year. A 10% overload capability is available for a period of 1 hour within a 12 hours period of operation. Total operating time at the 10% overload power shall not exceed 25 hours per year.

COP(CONTINUOUS POWER) is defined as being the maximum power which the generating set is capable of delivering continuously whilst supplying a constant electrical load when operated for an unlimited number of hours per year under the agreed operating conditions with the maintenance intervals and procedures being carried out as prescribed by the manufacturer.

※ Specifications are subject to change without prior notice.