

DP180LB

DESCRIPTION

- Easy installation, high performance, fuel efficiency and durability, which engine users always look for, are in DP180 L-Series engine.
- With Hyundai's engineering expertise, DP180 L-Series engines obtain the maximum power output and fuel efficiency while maintaining mechanical type that helps customers manage an engine more easily and conveniently.
- The most appealing part is simple design minimizing an impact of installation and maintenance.

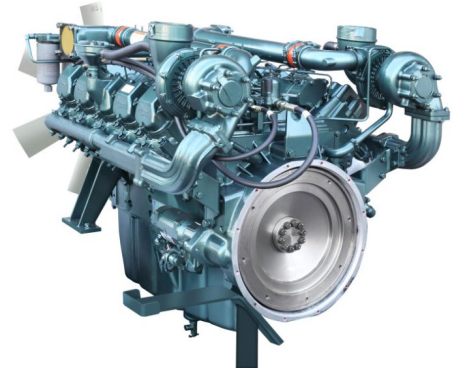

FEATURES & BENEFITS

[High Fuel Efficiency]

- Improved fuel efficiency
- Fuel consumption reduction thanks to stable combustion

[High Durability]

- New and strengthened key parts
- Improved durability with reinforced exhaust manifold
- High performance radiator

[Easy Installation]

- Redesigned engine mounting bracket
- Repositioned turbochargers
- Easy installation in cold region

[Easy Maintenance]

- Mechanical type engine
- Commonality of key parts

[Safety Design]

- New belt cover and heat screen for safety and beautification
- The fuel strainer is repositioned to secure sufficient space with the turbocharger so as to prevent fire caused by overheat of an engine

OUTPUT

1,500 RPM (50Hz)									1,800 RPM (60Hz)								
Standby			Prime			Continuous			Standby			Prime			Continuous		
kWm	kWe	kVA	kWm	kWe	kVA	kWm	kWe	kVA	kWm	kWe	kVA	kWm	kWe	kVA	kWm	kWe	kVA
612	563	704	556	510	638	389	352	440	661	602	753	601	545	681	421	375	469

- Generator efficiency (typical) : 94.5%
- kWm= kilo Watt mechanical, Gross power; kWe= kilo Watt electric = (kWm-Fan loss) x Generator eff.
kVA= kilo Volt Ampere
Calculations based on a 0.8 power factor = kWe/0.8

DP180LB

GENERAL DATA

Type	Diesel, Water cooled, Turbo charged & Intercooled
Bore	128mm
Stroke	142mm
Displacement liter	18.3
Cylinders and Arrangement	Cast iron, 10 Cylinder, Vee-Type
Battery charging alternator	27.5V x 45A alternator
Starting voltage	24V
Fuel system	Mechanical Injection Pump
Fuel filter	Full flow, Cartridge type with water drain valve.
Lube oil filter type (s)	Full flow, Cartridge type
Lube oil capacity (l)	Max. 34 liters , Min. 23 liters
Flywheel dimensions	SAE NO. 1M / Clutch NO. 14 M

COOLING SYSTEM

Cooling method	Jacket Water and Charge Air Cooled	
Cooling ratio	50% ethylene glycol; 50% water	
Water capacity (L)	with radiator	91liters
	Without radiator	21liters
Fan power (kW)	40kW(50Hz), 55kW(60Hz)	
Cooling system air flow (m ³ /min)	11.67(50Hz), 14.17(60Hz)	

FUEL CONSUMPTION

1,500 RPM (50Hz)

%	kWm	BHP	Liters/hr	USgal/hr
Standby Power				
100	612.0	820.7	149.5	39.49
Prime Power				
100	556.0	745.6	136.4	36.03
75	417.0	559.2	103.8	27.42
50	278.0	372.8	71.2	18.81
25	139.0	186.4	38.6	10.20
Continuous Power				
100	389.0			

1,800 RPM (60Hz)

%	kWm	BHP	Liters/hr	USgal/hr
Standby Power				
100	661.0	886.4	165.3	43.67
Prime Power				
100	601.0	805.9	150.7	39.81
75	450.8	604.5	114.2	30.17
50	300.5	403.0	77.7	20.53
25	150.3	201.5	41.2	10.88
Continuous Power				
100	421.0			

DP180LB

DIMENSIONS

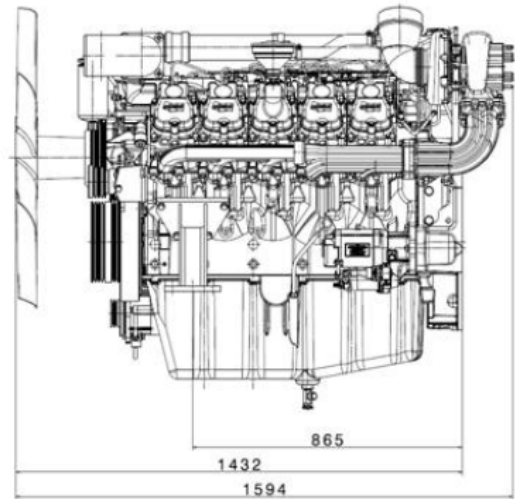
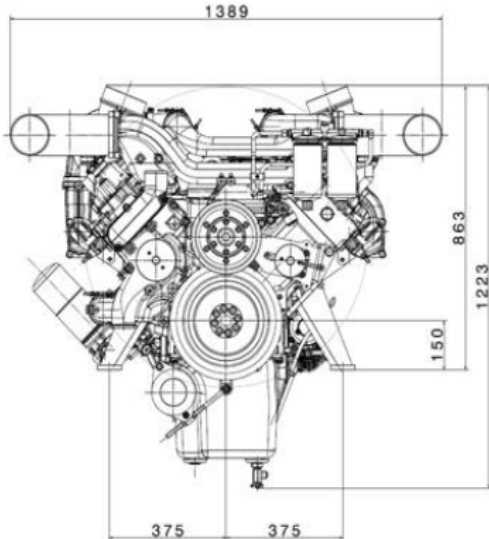

Weights and Dimensions

Item	Length (mm)	Width (mm)	Height (mm)	Dry Weight (kg)
Engine	1,594	1,389	1,223	1,250

POWER RATING GUIDE

The power ratings of Emergency Standby and Prime are in accordance with ISO 8528. Fuel Stop power in accordance with ISO 3046. Electric power (kWe) must be considered cooling fan loss, alternator efficiency, altitude derating and ambient temperature.

ESP (STANDBY POWER) is applicable for supplying emergency power for the duration of the utility power outage. No overload capability is available for this rating. A standby rated engine should be sized for a maximum of a 70% average load factor and 200 hours of operation per year. This includes less than 25 hours per year at the Standby Power rating.

PRP (PRIME POWER) is available for an unlimited number of hours per year in variable load application. Variable load should not exceed a 70% average of the Prime Power rating during any operating period of 24 hours. The Total operating time at 100% Prime Power shall not exceed 500 hours per year. A 10% overload capability is available for a period of 1 hour within a 12 hours period of operation. Total operating time at the 10% overload power shall not exceed 25 hours per year.

COP (CONTINUOUS POWER) is defined as being the maximum power which the generating set is capable of delivering continuously whilst supplying a constant electrical load when operated for an unlimited number of hours per year under the agreed operating conditions with the maintenance intervals and procedures being carried out as prescribed by the manufacturer.

※ Specifications are subject to change without prior notice.