



GENERATOR



21.9L / 12 CYLINDERS



SWITCHABLE

## DESCRIPTION

- HD Construction Equipment introduced new generator electronic engines DP222C- Series.
- When compared to other engines of equivalent capacity, it displays a higher output, better fuel efficiency, higher safety, and easier maintenance.
- Achieving precise fuel delivery with common rail system and electronic control unit(ECU), it allows optimal injection timing and pressure based on engine's current operating conditions.

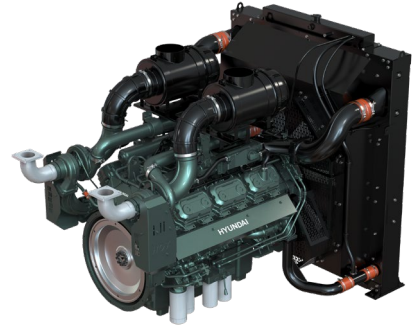

## FEATURES & BENEFITS

### [High Performance & Durability]

- G3 Class(ISO 8528-5)
- HVO/GTL : Usable up to 100%
- Robust main structure parts
- Oil maintenance interval: 500hrs without replenishment
- Operates without power derating up to an altitude of 1,000 meters
- Longer warranty period through strict verification

### [Convenience & Safety]

- 50/60 Hz switchable
- Maintenance free through auto tensioning belt drive system
- Radiator to cover a wide range of usage condition
- Safety guard for hazard parts
- Meet REACH & RoHS regulations

## OUTPUT

1,500 RPM (50Hz)									1,800 RPM (60Hz)								
Standby			Prime/DCP			Continuous			Standby			Prime/DCP			Continuous		
kWm	kWe	kVA	kWm	kWe	kVA	kWm	kWe	kVA	kWm	kWe	kVA	kWm	kWe	kVA	kWm	kWe	kVA
790	727	909	705	646	808	501	454	568	890	806	1008	810	730	913	578	511	639

- Generator efficiency (typical) : 94.5%
- kWm= kilo Watt mechanical, Gross power; kWe= kilo Watt electric = (kWm-Fan loss) x Generator eff.  
kVA= kilo Volt Ampere
- Calculations based on a 0.8 power factor = kWe/0.8

# DP222CB

## GENERAL DATA

Type	Diesel, Water cooled, Turbo charged & Intercooled
Bore	128mm
Stroke	142mm
Displacement liter	21.9 liter
Cylinders and Arrangement	Cast iron, 12 Cylinder, Vee type
Battery charging alternator	24V x 45A
Starting voltage	24V
Fuel system	Common rail, Direct injection controlled by ECU
Fuel filter	Full flow, Cartridge type
Lube oil filter type (s)	Full flow, Cartridge type
Lube oil capacity (l)	Max. 75 liters , Min. 23 liters
Flywheel dimensions	SAE NO.0 / Clutch NO.18"

## COOLING SYSTEM

Cooling method	Fresh water forced circulation	
Cooling ratio	50% ethylene glycol / 50% water	
Water capacity (L)	with radiator	66 liters
	without radiator	24 liters
Fan power (kW)	21 kW (1,500 rpm), 37 kW (1,800 rpm)	
Cooling system air flow (m <sup>3</sup> /min)	1,266 m <sup>3</sup> /min (1,500 rpm), 1,512 m <sup>3</sup> /min (1,800 rpm)	

## FUEL CONSUMPTION

1,500 RPM (50Hz)		
%	kWm	Liters/hr
<b>Standby</b>		
100	790.0	190.0
<b>Prime</b>		
100	705.0	168.0
75	528.8	127.0
50	352.5	93.0
25	176.3	50.0
<b>Continuous</b>		
100	501.0	128.0

1,800 RPM (60Hz)		
%	kWm	Liters/hr
<b>Standby</b>		
100	890.0	216.0
<b>Prime</b>		
100	810.0	204.0
75	607.5	155.0
50	405.0	117.0
25	202.5	60.0
<b>Continuous</b>		
100	578.0	145.0

# DP222CB

## DIMENSIONS

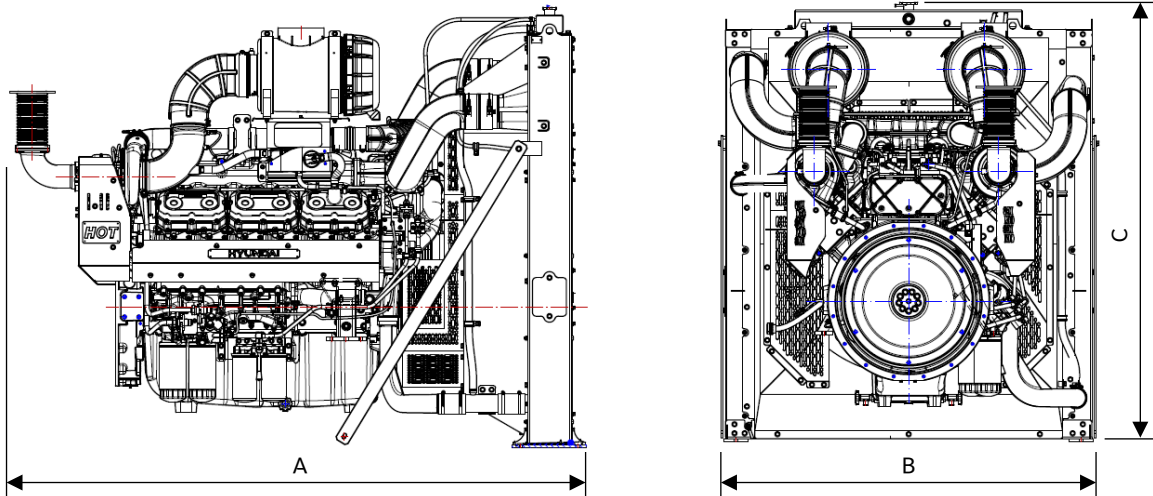

Weights and Dimensions (G-Pack)

Radiator Type	Length – A	Width – B	Height – C	Dry Weight
Ex-Tropical	2,556 mm	1,678 mm	1,946 mm	1,969 kg

## POWER RATING GUIDE

The power ratings of Emergency Standby and Prime are in accordance with ISO 8528. Fuel Stop power in accordance with ISO 3046. Electric power (kWe) must be considered cooling fan loss, alternator efficiency, altitude derating and ambient temperature.

**ESP(STANDBY POWER)** is applicable for supplying emergency power for the duration of the utility power outage. No overload capability is available for this rating. A standby rated engine should be sized for a maximum of an 70% average load factor and 500 hours of operation per year. This includes less than 25 hours per year at the Standby Power rating.

**PRP(PRIME POWER)** is available for an unlimited number of hours per year in variable load application. Variable load should not exceed a 70% average of the Prime Power rating during any operating period of 24 hours. The Total operating time at 100% Prime Power shall not exceed 500 hours per year. A 10% overload capability is available for a period of 1 hour within a 12 hours period of operation. Total operating time at the 10% overload power shall not exceed 25 hours per year.

**COP(CONTINUOUS POWER)** is defined as being the maximum power which the generating set is capable of delivering continuously whilst supplying a constant electrical load when operated for an unlimited number of hours per year under the agreed operating conditions with the maintenance intervals and procedures being carried out as prescribed by the manufacturer.

**DCP(DATA CENTRE POWER)** is available for variable or continuous electrical loads in a data centre application. Up to 100 percent load factor is permitted for unlimited time. DCP power definition relies on ISO 8528-1 2018 standard to be followed by generator set manufacturer, it will support Tier I to Tier IV classifications of data centres as per UPTIME institute guidelines. This definition is only back up a reliable utility. Continuous operation at load is available as after approval of Engine manufacturer.

※ Specifications are subject to change without prior notice.